

OPTICAL/HEAT MULTISENSOR DETECTOR



Product Overview	
Product Type	Optical/Heat Multisensor Detector
Part No.	DS-OTD01 (non-isolated)
	DS-OTD01 (isolated)
Digital Communication Protocol	Discovery & CoreProtocol® compatible

Product Information

The Optical/Heat Multisensor Detector uses new optical sensing technology, PureLight™, to detect smoke particles entering the chamber and is fitted with two thermistors for detecting heat. It can be switched to detect smoke, heat or a combination of both offering greater flexibility.

- Dual heat sensors
- PureLight optical technology reduces false alarms and enhances smoke recognition
- Utilises digital CoreProtocol communications Drift compensation
- Compatible with Discovery systems* Polycarbonate housing for colour stability and strength
- Mechanically compatible with existing bases
- Available with or without integrated switchable isolator
- Drift compensation
- Tri-coloured LED status indicator
- Polycarbonate moulding for colour stability and strength
- Tested to exceed EN 54-5 & EN 54-7 standards
- FasTest® for quicker testing of detectors
- Card addressing
- Locking mechanism (grub screw)

*Note: Not all features are available when devices are connected to an Discovery fire control panel

Technical Data	
All data is supplied subject to change without notice. Specifications are typical at 24V, 25°C and 50% RH unless otherwise stated.	
Detection principle	Smoke Photo-electric light scattering Heat Thermistor
Sensor configuration	Smoke Chamber with surface-mount infrared emitter and prism. Solid state integrated photo-diode and amplifier. Heat Dual exposed heat sensing elements
Sampling frequency	Once per second
Terminal functions (note: L1 & L2 are polarity sensitive)	+L2 Loop in & out positive -L1 in Loop (isolated) negative -L1 out Loop (isolated) negative +R Remote indicator positive connection (internal connection to positive) -R Remote indicator negative connection (4.7mA maximum)
Supply voltage (Vmin-Vmax)	17-35V DC
Digital communication protocol	Discovery & CoreProtocol compatible 5-13V peak to peak
Quiescent current	Isolated detector: 350µA Non-Isolated detector: 300µA
Power-up surge current	560µA
Maximum power-up time	10s
Alarm current, LED illuminated	3.5mA
Isolated detector data only	
Maximum loop current (ICmax; L1 in/out)	1A
Maximum series resistance (ZCmax; L1 in/out)	80m
Maximum switch current (ISmax; L1 in/out)	3A
Maximum leakage current (ILmax; during isolation)	33mA (100ms pulse every 2s)
Isolation voltage (VSOmin-VSOmax)	12.5-15V DC
Reconnect voltage (VSCmin-VSCmax)	12.8-19.1V DC
Clean-air analogue value	23 +4/-0
Alarm level analogue value	55
Status indicator	Alarm Red Fault Flashing Yellow Isolate Yellow Poll Green
Operating temperature	-40°C to 70°C

Continue

Technical Data		
Humidity	0% to 95% RH (no condensation or icing)	
Effect of atmospheric pressure	None	
Effect of wind speed	None, tested up to 10m/s	
Vibration, impact and shock	EN 54-5 & EN 54-7	
IP Rating	IP54	
Standards & approvals	SA5000-700 EN 54-5, EN 54-7, CPR & LPCB	SA5100-700 EN 54-5, EN 54-7, EN 54-17, CPR & LPCB
Dimensions	100mm diameter x 38.5mm height (50.5mm height with Intelligent Mounting Base)	
Weight	83g	
Materials	Housing: White polycarbonate Terminals: Tin plated stainless steel	

Electrical Considerations

The detector is designed to be connected to a two-wire loop circuit carrying both data and power. A version with a short-circuit isolator integrated into the detector head is also available.

Operating Principles

The low profile design of the Optical/Heat Multisensor Detector is sleek and evolutionary, with a 360° LED indicator which illuminates red when in alarm, yellow to indicate a fault and green to indicate protocol activity.

At the heart of the detector is PureLight Sensing Technology which incorporates:

- Cone technology combined with a high-intensity infra-red LED to provide stability and accurate sensitivity to smoke
- A photo-diode and an amplifier integrated into an Application-Specific Integrated Circuit (ASIC)
- 'Serpentine' pathway designed to provide a barrier against dust and insect ingress

A sophisticated dynamic algorithm, providing transient rejection and compensation for drift whilst maintaining accurate sensitivity

In addition to the optical smoke sensor, the Discovery Optical/Heat Multisensor Detector uses dual temperature sensors for improved reliability and is responsive in all detector orientations.

The independent signals from the optical smoke and heat sensors are combined in the detector microprocessor to produce an alarm decision according to the response mode chosen. With reference to Table 1, the five modes provide response behaviour which incorporates pure smoke detection, pure heat detection or a combination of both. The mode of operation of this processing is selected at the fire control panel.

Table 1 Discovery Optical Smoke Detector operating modes

Mode	Response Value		Minimum Time to Alarm Seconds
	%/m*	dB/m**	
1	1.4	0.10	5
2	1.4	0.10	30
3	2.1	0.14	5
4	2.1	0.14	30
5	2.4	0.16	5

* Tested in grey smoke

** Tested in oil mist to EN 54-7 standard

When the detector is operating as a multisensor (i.e. modes 1, 3 and 4) the temperature signal processing extracts only rate-of-rise information combined with the optical signal (see Table 1). In these modes the detector will not respond to a slow temperature increase, even if the temperature reaches a high level. A large sudden change in temperature can, however, cause an alarm without the presence of smoke.

Mode 5 has no smoke sensitivity at all, but gives a pure heat detector response meeting the response time requirements for a Class A1R detector in the European standard EN 54-5. In this mode the detector has a "fixed temperature" alarm threshold at 57°C, in addition to rate-of-rise characteristics.

Application

Fire detectors should always be installed in accordance with all local and national laws and codes of practice.

The detector can be switched between smoke and heat only modes making it suitable for a wide range of applications.

Device Addressing

A universal card is supplied with all Intelligent Mounting Bases. Using a coding guide, pips on the card are removed to set the address of the detector. This simplifies and speeds up installation, commissioning and maintenance. The address location remains the same no matter how often detectors are replaced.

When devices are used with CoreProtocol, device auto-addressing can be enabled by fire control panels that have been designed to incorporate this feature.

Communication

Device uses the new digital CoreProtocol to allow more advanced control and configuration, whilst maintaining backwards compatibility with previous generations of Discovery products. Discovery and CoreProtocol make use of the Normal, Read and Write modes with additional non-volatile data fields made available to the fire control panel.

Backward Compatibility

Detectors have been designed to operate on Discovery loops. This allows for detectors and bases to operate on existing systems and for detectors to operate on Discovery bases (Intelligent Mounting Base).

It should be noted that not all features of device will be available when used with Discovery fire control panels. If detectors are used with Discovery fire control panels incorporating drift compensation algorithms, these must be disabled when communicating with devices.

When detectors are used with an Intelligent Mounting Base on a CoreProtocol system, devices will have a +128 address offset due to only 7 address pips being available on the card. For example, an card set at 32 will address as 160 on CoreProtocol with detectors.

Maintenance & Service

Detectors have been designed with a comprehensive set of features to support maintenance and service, from self test capabilities to drift compensation warnings on dirty detectors. The new FasTest® mode facility on device can be enabled within a fire control panel that incorporates this feature. This facilitates quicker testing of detectors with appropriate test equipment. FasTest disables the transient rejection algorithms to allow a faster detector response, whilst ensuring the detectors absolute sensitivity remains identical to mode 3. A visual pass/fail indication is provided by the detector and overall, FasTest reduces commissioning and maintenance time.

Maintenance has to be performed in accordance with all applicable standards. Clean the detector externally using a soft damp cloth. For full cleaning and recalibration detectors should be returned to Discovery Fire Detectors.

EMC Directive 2004/108/EC

The Optical/Heat Multisensor Detector complies with the essential requirements of the EMC Directive 2004/108/EC, provided that it is used as described in this datasheet.

A copy of the Declaration of Conformity is available from Discovery on request.

Conformity of the Optical/Heat Multisensor Detector with the EMC Directive does not confer compliance with the directive on any apparatus or systems connected to it.

Construction Products Regulation 305/2011

The Optical/Heat Multisensor Detector complies with the essential requirements of the Construction Products Regulation 305/2011. A copy of the Declaration of Performance is available from Discovery on request.

Figure 1 Discovery Optical Smoke Detector with Intelligent Mounting Base dimensional drawing

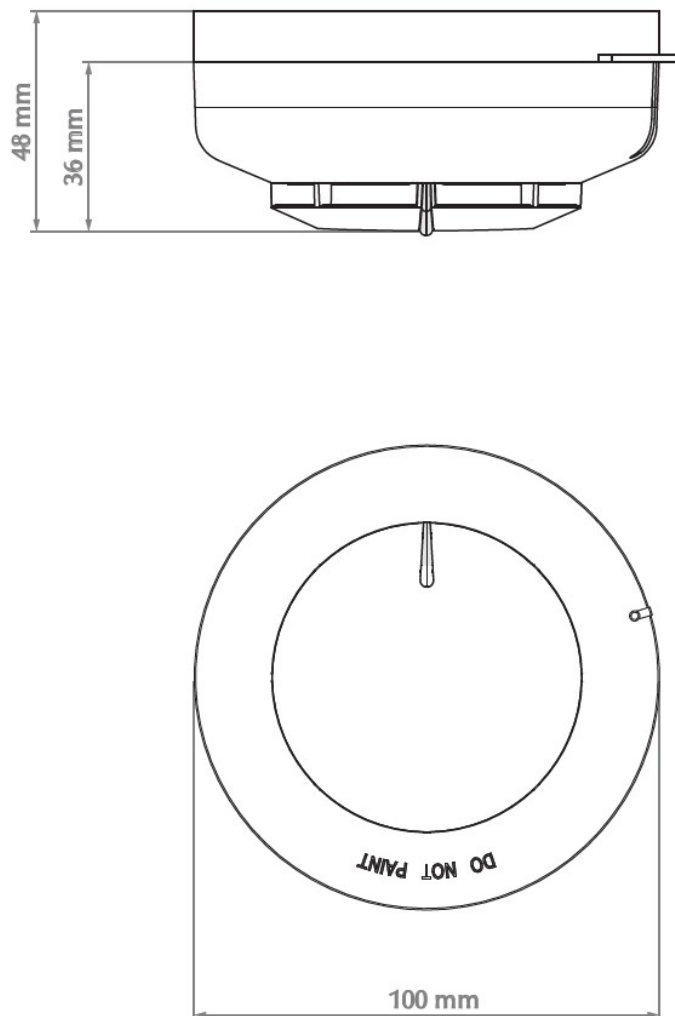

Figure 2 Intelligent Mounting Base

